

# PEFS Series

Rapid Shutdown (DC24V)

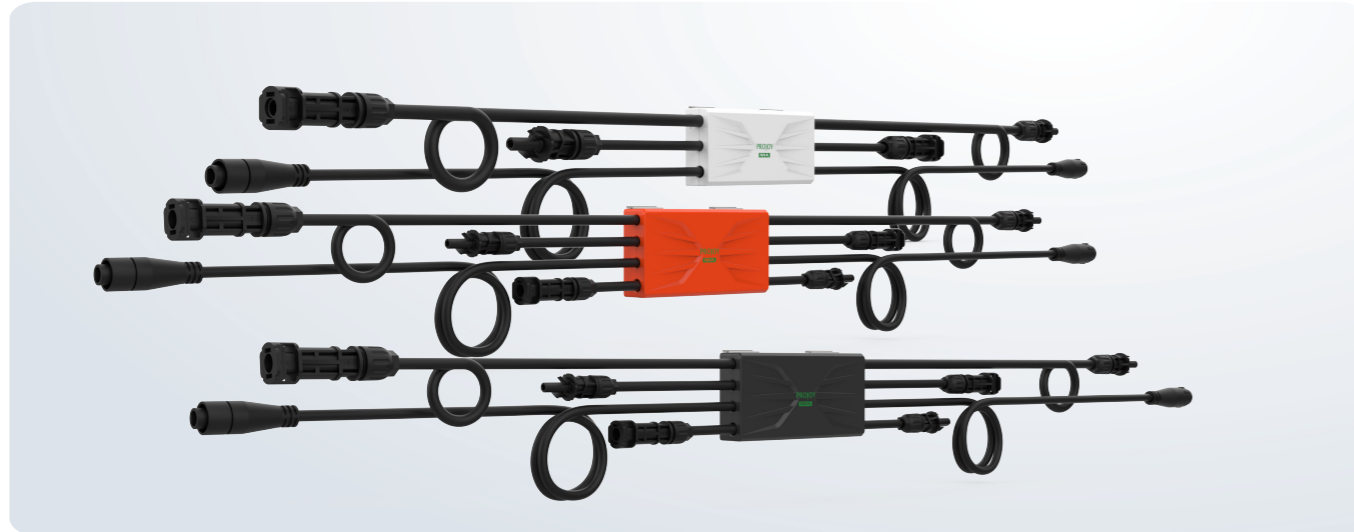

High Craftsmanship and Standards



Over temperature protection  $\geq 85^{\circ}\text{C}$



Max 20A support



Flame retardant: UL94-V0



Ingress protection:  $> \text{IP68} / \text{NEMA 4X}$



Anti-interference with high reliability and stability



long lifespan for 25 years



Compatible with all inverter brands and friendly for EMC Slim Design, Extremely Easy Installation

## Select Code

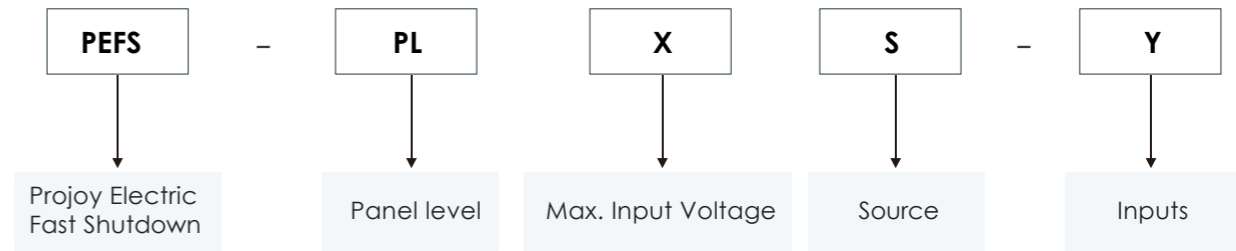

## Technical data

Type	PEFS-PL80S-11	PEFS-PL80S-21	PEFS-PL120S-11	PEFS-PL120S-21
Number of PV Inputs	1	2	1	2
Number of Modules Recommend	1	2	2	4
Maximum Allowed Input Voltage	80V	80V	120V	120V
Maximum Allowed Input Current	15A / 20A			
Maximum Output Voltage	80V	160V	120V	240V
System Voltage	1000V / 1500V			
Control Compliance	24VDC + 2 x 0.8mm <sup>2</sup> Cable			
Control Requirements	21.6V~26.4V at nomi. 27~36mA/unit			
Ambient Operating Temperature	-30° C to +60° C			
Protection Temperature	85° C			
IP Level	$> \text{IP68}$ , NEMA 4X			
Fire-proof Level	Flame retardant, UL94-V0			
Humidity	0%~90%			
PV Connectors	MC4 (Customized)			
Design Life Span	25 years			
Size	120*51.9*22.4mm	120*59*22.4mm	120*51.9*22.4mm	120*59*22.4mm
Weight	$< 200\text{g}$ (Excluding Cables)			
Cable Length, PV1+ Input	120mm	120mm	1200mm	120mm
Cable Length, PV1- Input	1200mm	1200mm	1200mm	2400mm
Cable Length, PV2+ Input	/	1200mm	/	2400mm
Cable Length, PV2- Input	/	120mm	/	120mm
Cable Length, Power Output	650mm+650mm	1250mm+1250mm	1250mm+1250mm	2450mm+2450mm
Cable Length, 24Vdc Control Cable	650mm+650mm	1250mm+1250mm	1250mm+1250mm	2450mm+2450mm
Standard Compliance	NEC2017/2020 (690.12); UL1741; UL3741; IEC/EN62109; IEC/EN61000			

## Tripping Ways

### Porjoy RSD Overview

The Porjoy RSD is designed to be installed at solar panel level and provides safety shutdown of the DC supply to ZERO VOLTS in case of emergency. Shutdown is initiated in 3 ways - Manual Operation, AC Supply Cut-Off or Temperature Rise Trigger as follows:

#### Temperature Rise Trigger

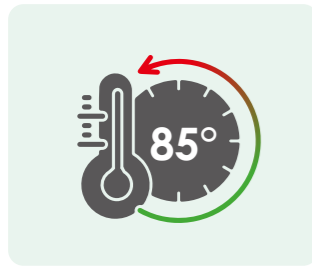

Automatic shutdown occurs if the temperature sensor on board of the RSD detects an ambient temperature rise above 85°C.

#### AC Supply Cut-Off

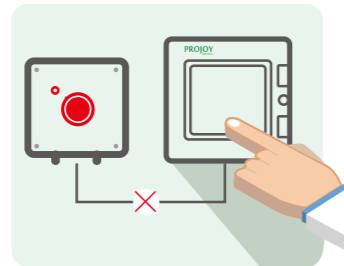

Disconnection of the external AC supply, by whatever means, causes automatic remote operation of the Emergency Rapid Shutdown Switch and solar panel shutdown.

#### Manual Operation

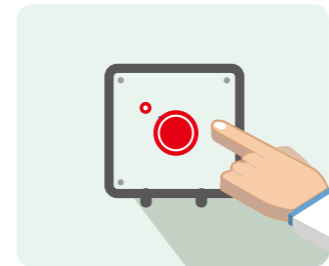

Manual shutdown is initiated within less than 0.1 second of operation by pressing the emergency pushbutton on the Emergency Rapid Shutdown Switch. The Emergency Switch can be conveniently located at ground level for easy access or multiple switches can be installed in different multi-level building zones.

#### Inverter Compatibility

The RSD is compatible with all string inverters and does not affect their operation or performance in any way.

#### Fail-Safe Operation

The RSD is designed for fail-safe operation ensuring that, will not compromise the solar panel isolation and shutdown status, maintaining full zero volt isolation.

#### Emergency Shutdown Switches

The Emergency Shutdown Switches offer a 24VDC power supply suitable for up to 480 panels operation, with LED indicator to signal.

#### North American Solar Market Approvals

The RSD has been extensively tested by ETL to meet the various PV standards required within the North American market.

#### UL1741 PVRSE Certification

The RSD is fully certified to UL1741 PVRSE (PV Rapid Shutdown Equipment) for applications. As a dedicated RSD operating as a safety switching without communications protocols, which is compatible with any PV inverter unit.

#### UL1741 Forthcoming AFCI Compatibility Requirements

The RSD is qualified to use with a number of solar inverters in accordance with the new UL AFCI specifications intended to ensure that the RSD operation does not interfere with the inverter's on board arc fault detection function. The RSD as a benign unit without PLC helps ensures that arc fault detection is in no way compromised as a result of its installation.

#### UL3741 PVRSS Certification

The RSD is fully certified to UL3741 PVRSS (PV Rapid Shutdown System) for applications. As a dedicated RSD operating as a safety switching without communications protocols, which is compatible with any PV inverter unit.

#### SunSpec Compliance

The SunSpec Interoperability Specification specifically provides for the exemption of products such as the RSD, stating at Section 1:  
"It is possible to achieve NEC compliance without a Rapid Shutdown System communication protocol. This specification does not apply in that case."

**PEFS-PL Series**

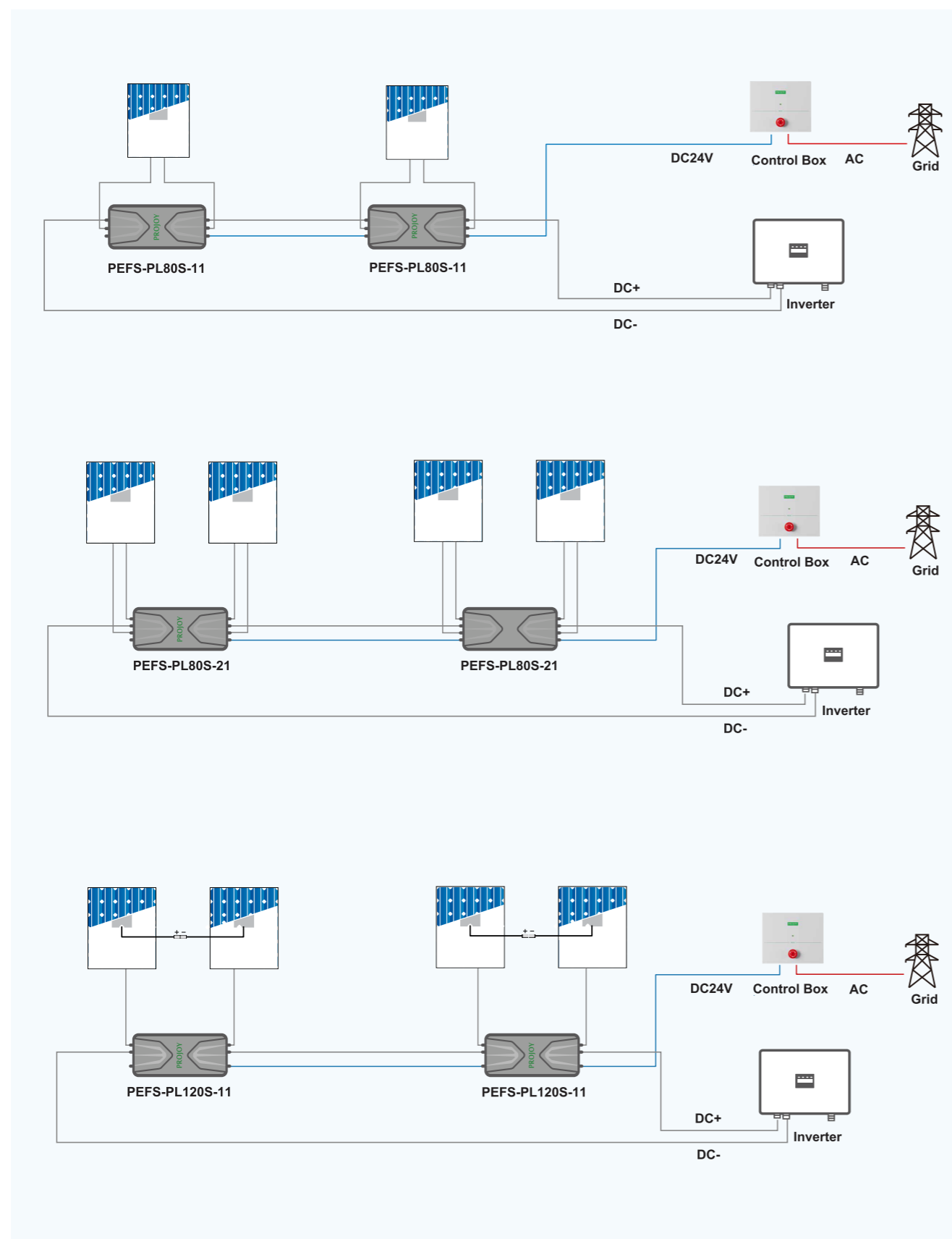

**PEFS-PL Series**

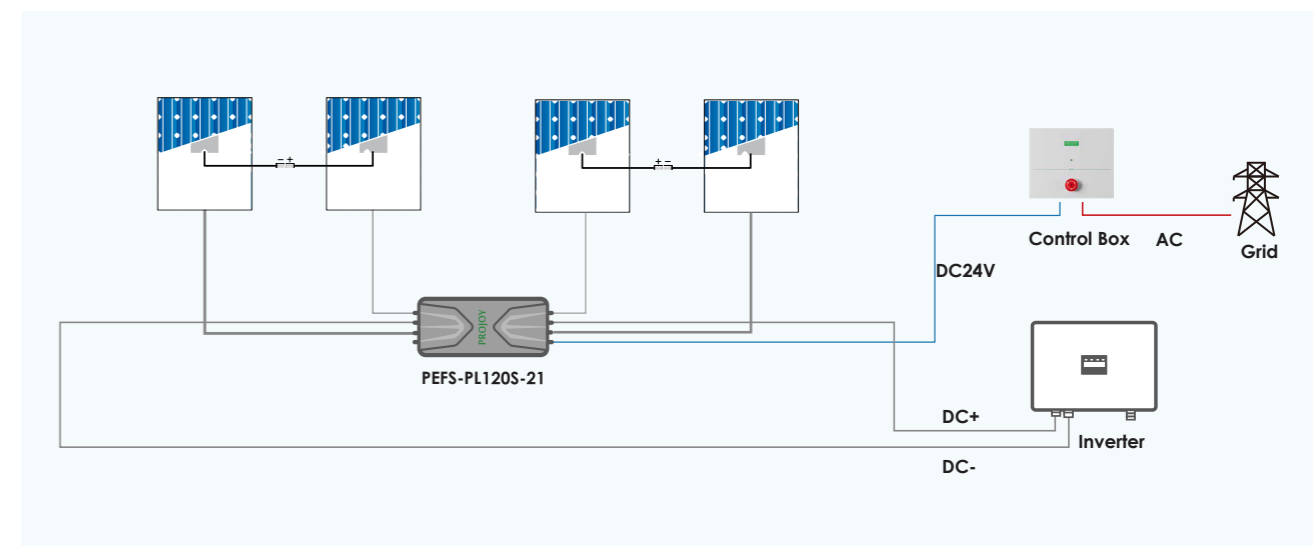

**Dimension**

